

MODULAR DESIGN

The choice is yours

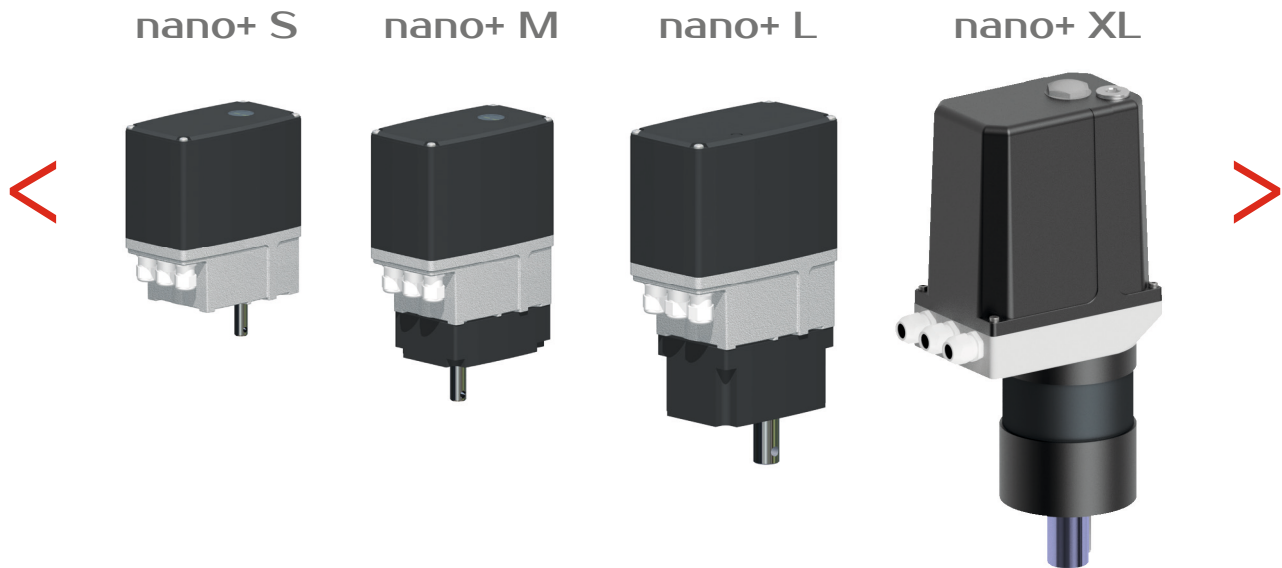

The **nano+** offers classic actuator technology

The powder-coated aluminum hood of the **nano+** combined with the equally powder-coated base unit guarantees a carefree and secure use, even in rough industrial environments. In addition, locking control cams ensure safe actuator cut-off in its set position, even in case of strong vibrations. The availability of different metal hood variants makes possible many additional optional multi-turn applications, up to fail-safe functions. The brand new XL equipment variant of the **nano+** product range combines now high torques of up to 500Nm with fast regulating times.

Test institutes confirmed the suitability for the electronic circuit according to DIN EN 12067-2 (optional) and/or in potentially explosive areas of Zone 2 or 22 (optional). The allrounder Nano+ is available in voltages of 230 V, 115 V, 24 V AC or 24 V DC and offers an almost unrestricted application in all industrial applications.

nano+ XL

TECHNICAL DATA

	AC	DC
Motor	Synchronous motor, short-circuit proof	Direct current brush motor
Protection class	IP 65 (optional IP 66)	
Ambient temperature	-15 °C...+60 °C/optional -40 °C...+80 °C (with PMR: 0 °C...+60 °C)	
Housing	Aluminium silver anodized	
Gear	Case hardened metal	
Cover	Aluminium powder-coated	
Shaft	1.1191	
Position indicator	Standard	
Power supply	230 V AC (optional 115 V AC/24 V AC)	24 V DC ±20%
Additional switches	2 or 4 pieces (optional)	
Potentiometer	optional	
Travel	10°...330°	
Duty cycle	S1	
Connection	3 cable glands M20x1,5	
Travel cutoff	Switching cams/Micro switches	
Maintenance	Maintenance-free	
Control	3-point-step	2-wire-technology

TYPE LIST

Type	AC		Type	DC	
	Torque [Nm]	Actuating time [s/90°]		Torque [Nm]	Actuating time [s/90°]
nano+ XL 250-20	250	20 (17)	nano+ XL 200-40	200	40
nano+ XL 250-30	250	30 (25)	nano+ XL 200-60	200	60
nano+ XL 250-140	250	140 (117)	nano+ XL 200-75	200	75
nano+ XL 300-30	300	30 (25)	nano+ XL 350-50	350	50
nano+ XL 300-40	300	40 (34)	nano+ XL 350-60	350	60
nano+ XL 300-75	300	75 (63)	nano+ XL 350-75	350	75
nano+ XL 400-60	400	60 (50)	nano+ XL 450-50	450	50
nano+ XL 400-90	400	90 (75)	nano+ XL 500-60	500	60
nano+ XL 400-140	400	140 (117)	nano+ XL 500-75	500	75
nano+ XL 500-35	500	35 (30)			
nano+ XL 500-60	500	60 (50)			
nano+ XL 500-90	500	90 (75)			
nano+ XL 500-150	500	150 (125)			

Values in () = 60 Hz

Other values upon request

DIMENSIONS

nano+ XL

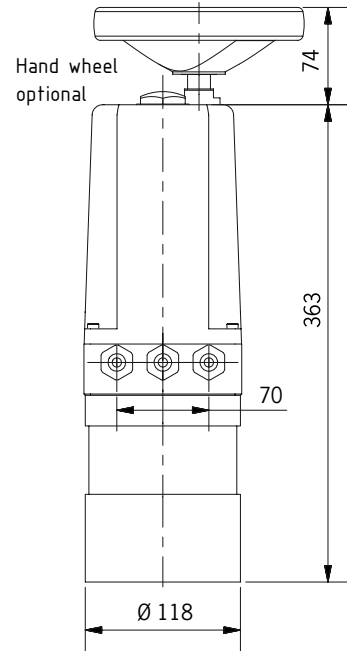
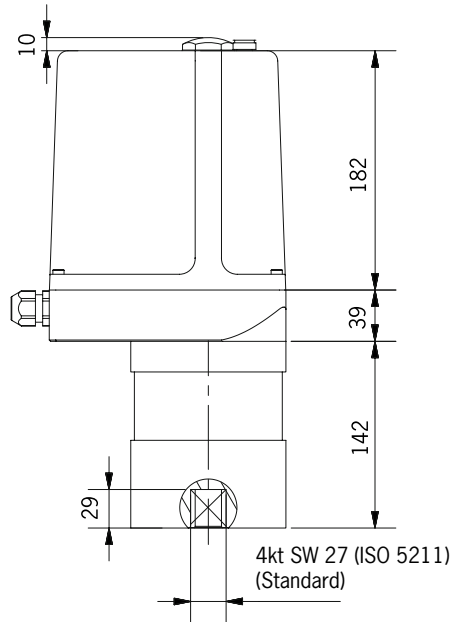

Cable glands optional
(Standard=Blind plugs)

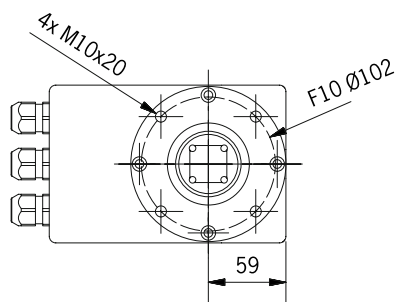
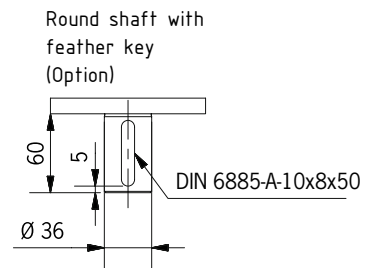
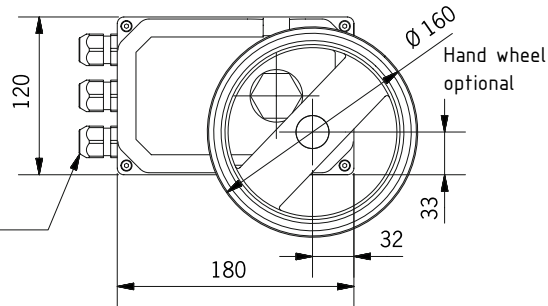

nano+

The perfect solution
from ARIS

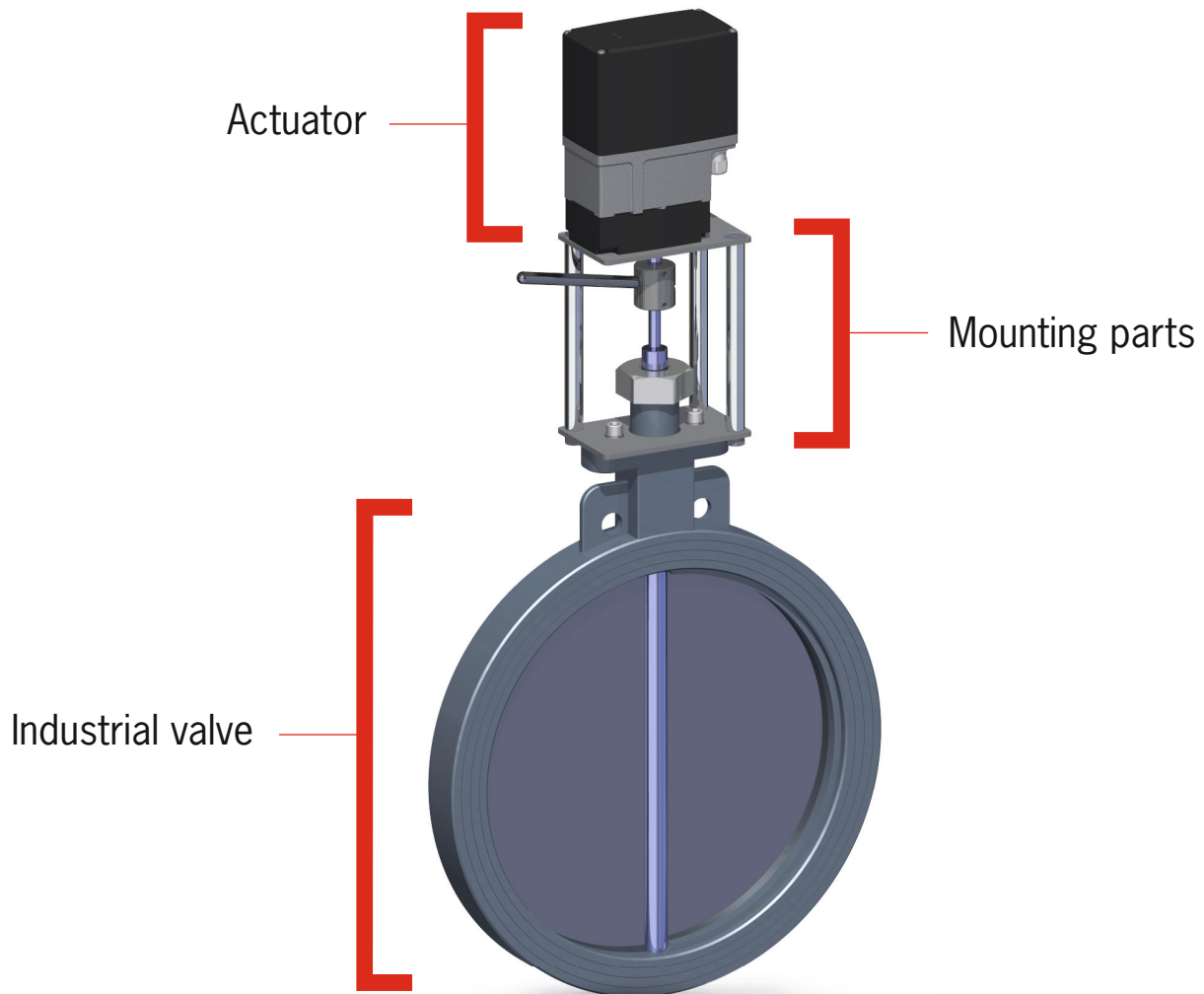

ARIS is your competent partner for innovative and durable drive technology. Our team will be glad to help you with the design and dimensioning of your drive solution.

Our technicians will calculate your entire unit consisting of the actuator head, valve actuator, valve, fitting and add-on modules. The system components are completely assembled, pre-configured and tested prior to delivery.

Come to ARIS – **Your specialist for modern drive technology “Made in Germany”**